

Technical Specifications

Power Supply

- 1 phase 220...240 VAC $\pm 15\%$
- 3 phase 220...240 VAC $\pm 15\%$
- 3 phase 380...480 VAC $+10\%$ -15 %
- Input frequency 50/60 Hz

Overloads

- Starting torque 150 % for 60 s, 200 % for 3 s

Output Frequency

- 0.5...590 Hz
- Digital resolution 0.01 Hz

Inputs/Outputs

- Analogue Inputs 2: (0-5 V, 0-10 V, 0-20 mA)
- Analogue Output 1: (0-5 V, 0-10 V, 0-20 mA, 4-20 mA)
- Digital Inputs 6: Nominal 24 VDC
- Digital Output 1: Nominal 24 VDC
- Relay Output 1: Volt free contact, 5 A @230 VAC max.

Standards

AC10 IP66 meets the following standards when installed in accordance with the information provided in the relevant product manual

- CE marked to EN50178 (Safety, Low-Voltage Directive)
- CE marked to EN61800-3 (EMC Directive)

Operating Range

- Ambient operating temperature 0...50 °C
- Altitude 1000 m ASL
- Humidity 0...90 %, non-condensing, non-corrosive

Environment

- Conformally coated PCBs as standard achieving 3C3 environmental conformance
- Optional internal C3 EMC filter meets the requirements of EN61800-3 (industrial environment)

Switching Frequency

- Output switching frequencies 2...10 kHz, 4 kHz nominal

Ratings

220 V Single Phase Input / 230 V Three phase Input		
Nominal Power [kW]	Output Current [A]	Frame Size
0.4	2.5	1
0.75	4.5	1
1.5	7	1
2.2	10	1

400 V Three phase Input		
Nominal Power [kW]	Output Current [A]	Frame Size
0.75	2	1
1.5	4	1
3	7	1
4	9	1
5.5	12	2
7.5	17	2
11	23	3
15	32	3

Dimensions [mm]

Frame	Height (H)	Width (W)	Depth (D)
1	412	200	198
2	418	242	198
3	471	242	228

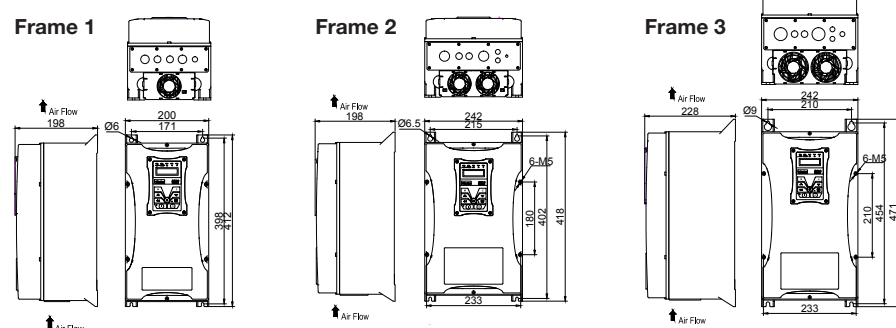

Parker Worldwide

Europe, Middle East, Africa

AE – United Arab Emirates, Dubai
Tel: +971 4 8127100
parker.me@parker.com

AT – Austria, Wiener Neustadt
Tel: +43 (0)2622 23501-0
parker.austria@parker.com

AT – Eastern Europe, Wiener Neustadt
Tel: +43 (0)2622 23501 900
parker.easteurope@parker.com

AZ – Azerbaijan, Baku
Tel: +994 50 2233 458
parker.azerbaijan@parker.com

BE/LU – Belgium, Nivelles
Tel: +32 (0)67 280 900
parker.belgium@parker.com

BG – Bulgaria, Sofia
Tel: +359 2 980 1344
parker.bulgaria@parker.com

BY – Belarus, Minsk
Tel: +375 17 209 9399
parker.belarus@parker.com

CH – Switzerland, Etoy
Tel: +41 (0)21 821 87 00
parker.switzerland@parker.com

CZ – Czech Republic, Klecany
Tel: +420 284 083 111
parker.czechrepublic@parker.com

DE – Germany, Kaarst
Tel: +49 (0)2131 4016 0
parker.germany@parker.com

DK – Denmark, Ballerup
Tel: +45 43 56 04 00
parker.denmark@parker.com

ES – Spain, Madrid
Tel: +34 902 330 001
parker.spain@parker.com

FI – Finland, Vantaa
Tel: +358 (0)20 753 2500
parker.finland@parker.com

FR – France, Contamine s/Arve
Tel: +33 (0)4 50 25 80 25
parker.france@parker.com

GR – Greece, Athens
Tel: +30 210 933 6450
parker.greece@parker.com

HU – Hungary, Budaörs
Tel: +36 23 885 470
parker.hungary@parker.com

IE – Ireland, Dublin
Tel: +353 (0)1 466 6370
parker.ireland@parker.com

IT – Italy, Corsico (MI)
Tel: +39 02 45 19 21
parker.italy@parker.com

KZ – Kazakhstan, Almaty
Tel: +7 7273 561 000
parker.easteurope@parker.com

NL – The Netherlands, Oldenzaal
Tel: +31 (0)541 585 000
parker.nl@parker.com

NO – Norway, Asker
Tel: +47 66 75 34 00
parker.norway@parker.com

PL – Poland, Warsaw
Tel: +48 (0)22 573 24 00
parker.poland@parker.com

PT – Portugal, Leca da Palmeira
Tel: +351 22 999 7360
parker.portugal@parker.com

RO – Romania, Bucharest
Tel: +40 21 252 1382
parker.romania@parker.com

RU – Russia, Moscow
Tel: +7 495 645-2156
parker.russia@parker.com

SE – Sweden, Spånga
Tel: +46 (0)8 59 79 50 00
parker.sweden@parker.com

SK – Slovakia, Banská Bystrica
Tel: +421 484 162 252
parker.slovakia@parker.com

SL – Slovenia, Novo Mesto
Tel: +386 7 337 6650
parker.slovenia@parker.com

TR – Turkey, Istanbul
Tel: +90 216 4997081
parker.turkey@parker.com

UA – Ukraine, Kiev
Tel: +380 44 494 2731
parker.ukraine@parker.com

UK – United Kingdom, Warwick
Tel: +44 (0)1926 317 878
parker.uk@parker.com

ZA – South Africa, Kempton Park
Tel: +27 (0)11 961 0700
parker.southafrica@parker.com

North America

CA – Canada, Milton, Ontario
Tel: +1 905 693 3000

US – USA, Cleveland
Tel: +1 216 896 3000

Asia Pacific

AU – Australia, Castle Hill
Tel: +61 (0)2-9634 7777

CN – China, Shanghai
Tel: +86 21 2899 5000

HK – Hong Kong
Tel: +852 2428 8008

IN – India, Mumbai
Tel: +91 22 6513 7081-85

JP – Japan, Tokyo
Tel: +81 (0)3 6408 3901

KR – South Korea, Seoul
Tel: +82 2 559 0400

MY – Malaysia, Shah Alam
Tel: +60 3 7849 0800

NZ – New Zealand, Mt Wellington
Tel: +64 9 574 1744

SG – Singapore
Tel: +65 6887 6300

TH – Thailand, Bangkok
Tel: +662 186 7000-99

TW – Taiwan, Taipei
Tel: +886 2 2298 8987

South America

AR – Argentina, Buenos Aires
Tel: +54 3327 44 4129

BR – Brazil, Sao Jose dos Campos
Tel: +55 800 727 5374

CL – Chile, Santiago
Tel: +56 2 623 1216

MX – Mexico, Toluca
Tel: +52 72 2275 4200

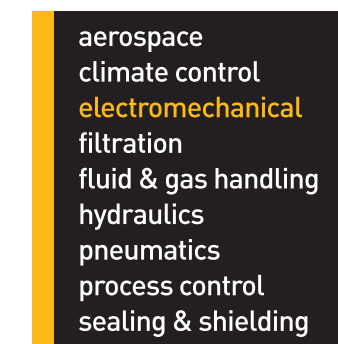
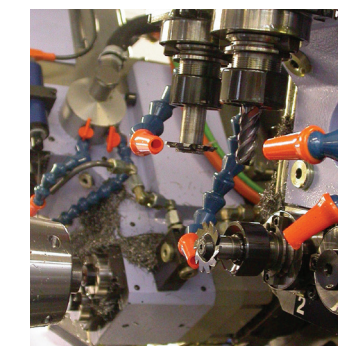

AC10 Variable Speed Drive

For Simple, Reliable Motor Control in General Purpose Applications
0.4 - 15 kW IP66 Compact Drive

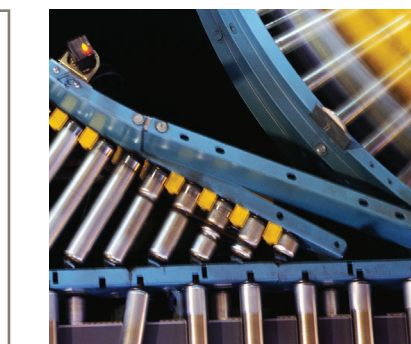

We reserve the right to make technical changes. The data correspond to the technical state at the time of printing.
© 2014 Parker Hannifin Corporation. All rights reserved.

192-300028N1

November 2013



EMEA Product Information Centre
Free phone: 00 800 27 27 5374
(from AT, BE, CH, CZ, DE, DK, EE, ES, FI, FR, IE, IL, IS, IT, LU, MT, NL, NO, PL, PT, RU, SE, SK, UK, ZA)
US Product Information Centre
Toll-free number: 1-800-27 27 537
www.parker.com

Your local authorized Parker distributor



ENGINEERING YOUR SUCCESS.

AC10 Variable Speed Compact Drive

0.4 – 15 kW IP66

Overview

AC10 IP66 drive is a simple, reliable and economical solution to every-day motor control applications where protection against the ingress of dust and moisture is required. AC10 offers speed or torque control within the power range of 0.4 kW to 15 kW. Having features normally only associated with higher specification

drives, including; IP66 protective enclosure, sensorless vector mode, output frequency up to 590 Hz and 3 phase 400 volt supplies in all 5 frame sizes, AC10 IP66 provides an optimised solution for OEM machine builders looking for a compact, cost-effective IP66 drive without compromising on performance.

IP66 / NEMA 4x apply to IEC standard 60529-2004 and assess the capability of an enclosure to resist specific environmental conditions. IP66 protection represents dust tight performance as well as the ability to withstand powerful water jets from all directions. Parker AC10 IP66 offers all the great benefits of the AC10 series drives but with added environmental protection.

Simplicity

AC10 IP66 is designed to reduce the time and effort required to install, setup and commission through its easy to use integrated keypad. Minimal wiring requirements and two easily accessed terminal rails make AC10 IP66 fast and simple to install, having you up and running in no time at all. Auto-tuning sensorless vector mode takes AC10 IP66 beyond simple V/Hz control allowing users requiring greater dynamic speed or torque control for their application to benefit from the drives enhanced 0.5 % speed and 5 % torque accuracy.

Reliability

Proven technology and manufacturing techniques ensure AC10 IP66 has been engineered and built to deliver consistently outstanding levels of performance day in, day out ensuring maximum uptime and productivity. Thanks to its conformally coated PCBs, AC10 IP66 is able to withstand even the most arduous class 3C3 environment which many other drives in this class would struggle with, allowing you to operate AC10 IP66 with the utmost confidence in more applications.

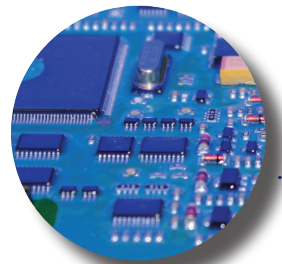

Suited to all environments

- Robust IP66 rated enclosure for environmental protection
- Optional Internal EMC filter allows use in C3 industrial environments
- Conformal coating provides protection in arduous class 3C3 environments
- 50 °C operating temperature



Extra power when it's needed

- 150 % overload for 60 seconds at 0.5 Hz to provide extra starting torque for shifting high inertia loads
- Output power can be uprated for operation in lower ambient temperatures



All at the touch of a button

- Standard ergonomic keypad providing full access to all drive functions
- Simple out of the box operation thanks to integrated macros and quick start guide

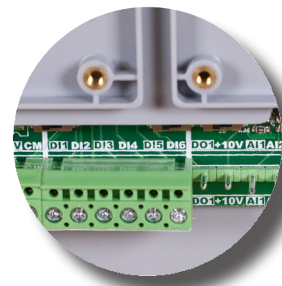

Flexible Connections

- Freely assignable digital inputs and outputs, and relay output to suit your application needs
- Internal dynamic brake switch as standard
- Connection to PLC or other Modbus RTU / RS485 network

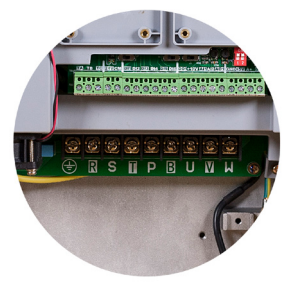

Easy Connection Access

- Easy user access to connections with removable gland plate

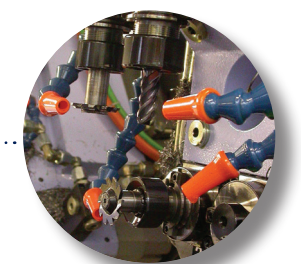

High Speed Operation

- Up to 590 Hz output for high speed operations such as spindles, centrifuges, mixers etc.

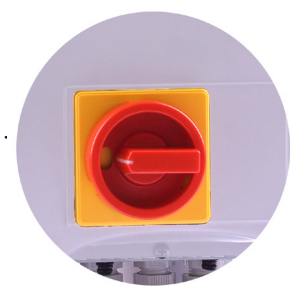

Customisation Options

- User customisable option panel for:
 - Isolators
 - Switches
 - Push buttons
 - Indicators

Energy savings made simple

For applications such as fan control, energy savings of up to 50% can be achieved by using the AC10 IP66 to match the motor speed to process requirements.

In addition to saving energy, power factor can be improved, system noise reduced, maintenance periods extended and overall service life increased.

AC10 IP66 can be integrated close to the motor, regardless of the environmental conditions, saving in cabling costs, space and energy as well as the cost of separate cabinets.

Dependent upon the application, payback time can be as little as a few months.

More efficient

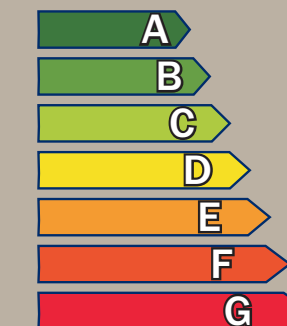

Less efficient

Applications

AC10 IP66 provides a no-fuss approach to general purpose industrial motor control applications across a wide range of industries. The IP66 enclosure enables use in both indoor and outdoor applications where environmental conditions may be a concern, such as wash-down areas in food and beverage facilities and use in waste plants or rooftop units.

Typical applications for AC10 include...

- Mixers
- Packaging Machines
- Textile Machines
- Conveyor
- Fans
- Spindles



Packaging Machines

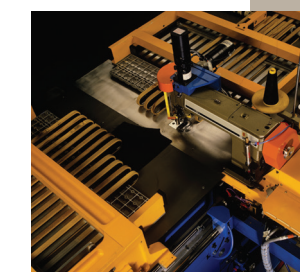

Textile Machines



Conveyors



Fans

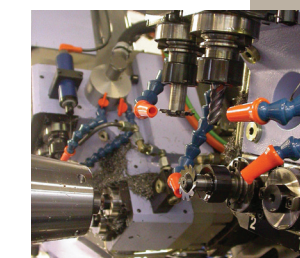

Spindles



Mixers