

ABB micro drives

ACS150, 0.37 to 4 kW/0.5 to 5 hp

ABB micro drives are designed to be incorporated into a wide variety of machines such as mixers, conveyors, fans or pumps or anywhere where a fixed speed motor needs to run at variable speed.



The ACS150 drives have an integrated user panel and potentiometer, and a variety of features such as macros, which are pre-defined I/O configurations like 3-wire, PID-control and motor potentiometer macro. In addition, the drives offer extensive range of parameters that help obtaining the best performance out of the application.

FlashDrop, an optional drive configuration tool designed for volume configuration, can be used to quickly and easily configure unpowered drives. FlashDrop stores up to 20 different drive parameter sets and can copy parameters from one drive to another, or between a PC and a drive.

Highlights

- Worldwide availability through logistical distributors
- User-friendly LCD user panel and integrated potentiometer
- Flexible mounting alternatives
- PID control
- Integrated EMC filter
- Built-in brake chopper
- FlashDrop tool for fast drive commissioning

Voltage and power range

- 1-phase, 200 to 240 V $\pm 10\%$
0.37 to 2.2 kW (0.5 to 3 hp)
- 3-phase, 200 to 240 V $\pm 10\%$
0.37 to 2.2 kW (0.5 to 3 hp)
- 3-phase, 380 to 480 V $\pm 10\%$
0.37 to 4 kW (0.5 to 5 hp)

Options

- FlashDrop tool
- Input/output chokes
- C2 EMC filters
- NEMA 1 enclosure kit

Applications

- Conveyors
- Mixers
- Material handling
- Fans and pumps

Technical data and types

Ratings			Type designation	Frame: IP20 UL open				NEMA 1				
P_N	P_N	I_{2N}		size	H2	W	D	Weight	H5	W	D	Weight
kW	hp	A		mm	mm	mm	kg	mm	mm	mm	kg	
1-phase AC supply, 200 - 240 V units												
0.37	0.5	2.4	ACS150-01X-02A4-2	R0	202	70	142	1.1	280	70	142	1.5
0.75	1	4.7	ACS150-01X-04A7-2	R1	202	70	142	1.3	280	70	142	1.7
1.1	1.5	6.7	ACS150-01X-06A7-2	R1	202	70	142	1.3	280	70	142	1.7
1.5	2	7.5	ACS150-01X-07A5-2	R2	202	105	142	1.5	282	105	142	1.9
2.2	3	9.8	ACS150-01X-09A8-2	R2	202	105	142	1.5	282	105	142	1.9
3-phase AC supply, 200 - 240 V units												
0.37	0.5	2.4	ACS150-03X-02A4-2	R0	202	70	142	1.1	280	70	142	1.5
0.55	0.75	3.5	ACS150-03X-03A5-2	R0	202	70	142	1.1	280	70	142	1.5
0.75	1	4.7	ACS150-03X-04A7-2	R1	202	70	142	1.3	280	70	142	1.7
1.1	1.5	6.7	ACS150-03X-06A7-2	R1	202	70	142	1.3	280	70	142	1.7
1.5	2	7.5	ACS150-03X-07A5-2	R1	202	70	142	1.3	280	70	142	1.7
2.2	3	9.8	ACS150-03X-09A8-2	R2	202	105	142	1.5	282	105	142	1.9
3-phase AC supply, 380 - 480 V units												
0.37	0.5	1.2	ACS150-03X-01A2-4	R0	202	70	142	1.1	280	70	142	1.5
0.55	0.75	1.9	ACS150-03X-01A9-4	R0	202	70	142	1.1	280	70	142	1.5
0.75	1	2.4	ACS150-03X-02A4-4	R1	202	70	142	1.3	280	70	142	1.7
1.1	1.5	3.3	ACS150-03X-03A3-4	R1	202	70	142	1.3	280	70	142	1.7
1.5	2	4.1	ACS150-03X-04A1-4	R1	202	70	142	1.3	280	70	142	1.7
2.2	3	5.6	ACS150-03X-05A6-4	R1	202	70	142	1.3	280	70	142	1.7
3	4	7.3	ACS150-03X-07A3-4	R1	202	70	142	1.3	280	70	142	1.7
4	5	8.8	ACS150-03X-08A8-4	R1	202	70	142	1.3	280	70	142	1.7

X within the type code stands for E or U.

E = EMC filter connected. U = EMC filter disconnected.

H2 = Height with fastenings but without clamping plate.

H5 = Height with fastenings, NEMA 1 connection box and hood.

W = Width

D = Depth

Control connections

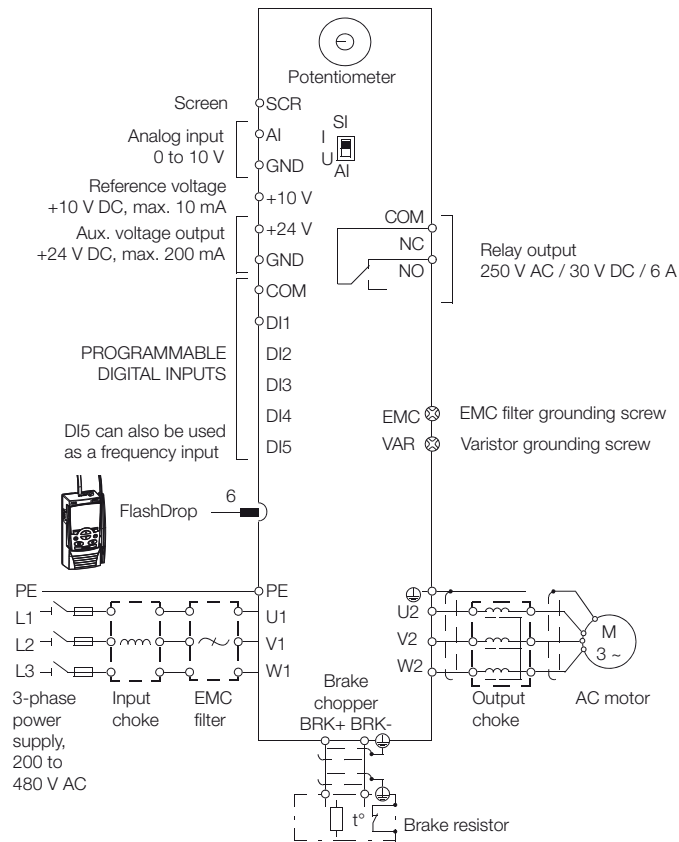

Mains connection

Voltage and power range	1-phase, 200 to 240 V $\pm 10\%$ 0.37 to 2.2 kW (0.5 to 3 hp) 3-phase, 200 to 240 V $\pm 10\%$ 0.37 to 2.2 kW (0.5 to 3 hp) 3-phase, 380 to 480 V $\pm 10\%$ 0.37 to 4 kW (0.5 to 5 hp)
--------------------------------	--

Frequency	48 to 63 Hz
------------------	-------------

Motor connection

Voltage	3-phase, from 0 to U_{supply}
Frequency	0 to 500 Hz
Overload capability (at a max. ambient temperature of 40 °C)	At heavy duty use $1.5 \times I_{2N}$ for 1 minute every 10 minutes At start $1.8 \times I_{2N}$ for 2 s
Switching frequency	
Default	4 kHz
Selectable	4 to 16 kHz with 4 kHz steps with derating Parameter-enabled noise cancellation function
Acceleration time	0.1 to 1800 s
Deceleration time	0.1 to 1800 s
Braking	Built-in brake chopper as standard
Auxiliary voltage	24 V DC $\pm 10\%$, max. 200 mA
Motor control method	Scalar U/f

Product compliance

UL, cUL, CE, C-Tick and GOST R approvals, RoHS compliant

Environmental limits

Degree of protection	IP20 / Optional NEMA 1 enclosure
Ambient temperature	-10 to 40 °C (14 to 104 °F), no frost allowed, 50 °C (122 °F) with 10% derating
Relative humidity	Lower than 95% (without condensation)

For more details see ACS150 catalog (3AFE68596114).

For more information please contact your local ABB representative or visit:

www.abb.com/drives

www.abb.com/drivespartners

© Copyright 2016 ABB. All rights reserved. Specifications subject to change without notice.